

HOW TO INSTALL DISTINCTIVE PILLARS

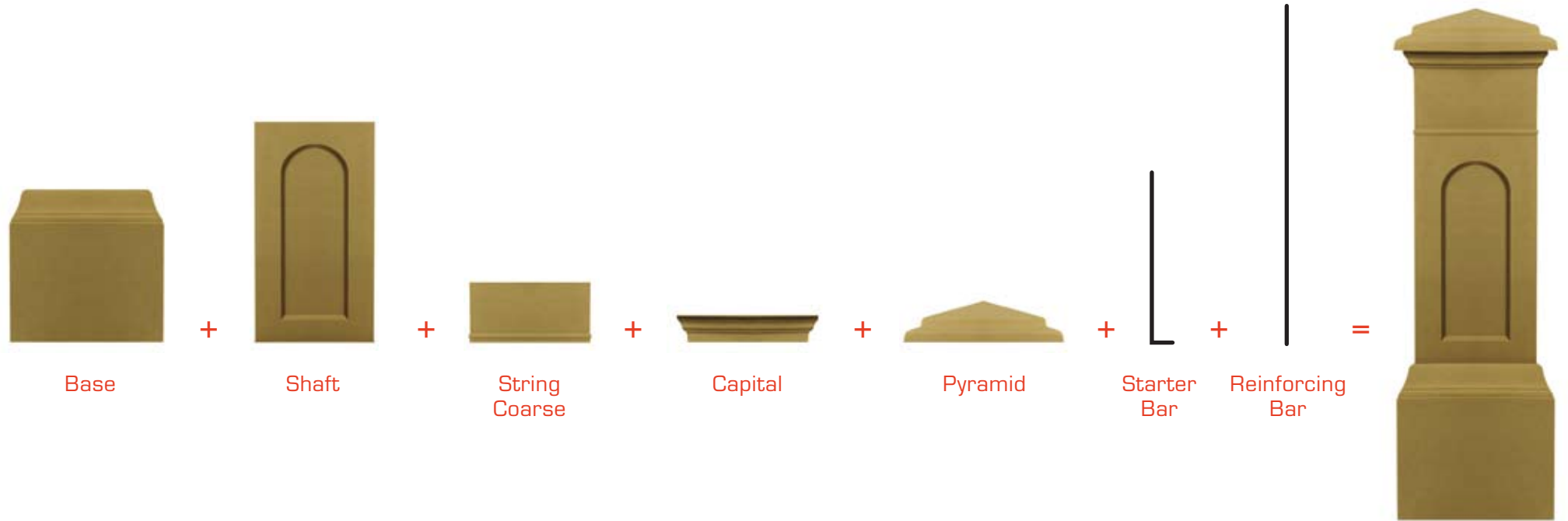

For each pillar

- Firstly, dig the foundations for your pillar:
Eastwood
700mm x 700mm x 600mm deep
Aldgate
500mm x 500mm x 400mm deep
- Fill hole with Mini Mix Concrete (20mm stone 20MPa) for correct consistency
- Insert **Starter Bar** into foundations
- Once foundations have hardened roll **Base** over **Starter Bar**

- Level and position to your requirements
- Run a line of glue/mortar around top of base where the **Shaft** is to fit
- Flip **Shaft** onto base by firstly positioning the bottom edge as shown below, and level the **Shaft** and place **Reinforcing Bar** into the **Shaft**
- Position and glue **String Coarse** on to top of **Shaft**

- Hose down inside of Gate Pillar, place **Reinforcing Bar** (N12) into centre of **Shaft**, fill to top of shaft with concrete. (You will need to fill **String Coarse** as well, if fence or gate is being mounted to that section.)
- Two N12 bars are required if swinging gates are to be attached
- Glue **Capital & Pyramid** into position
- For final finish flush all joints using matching mortar

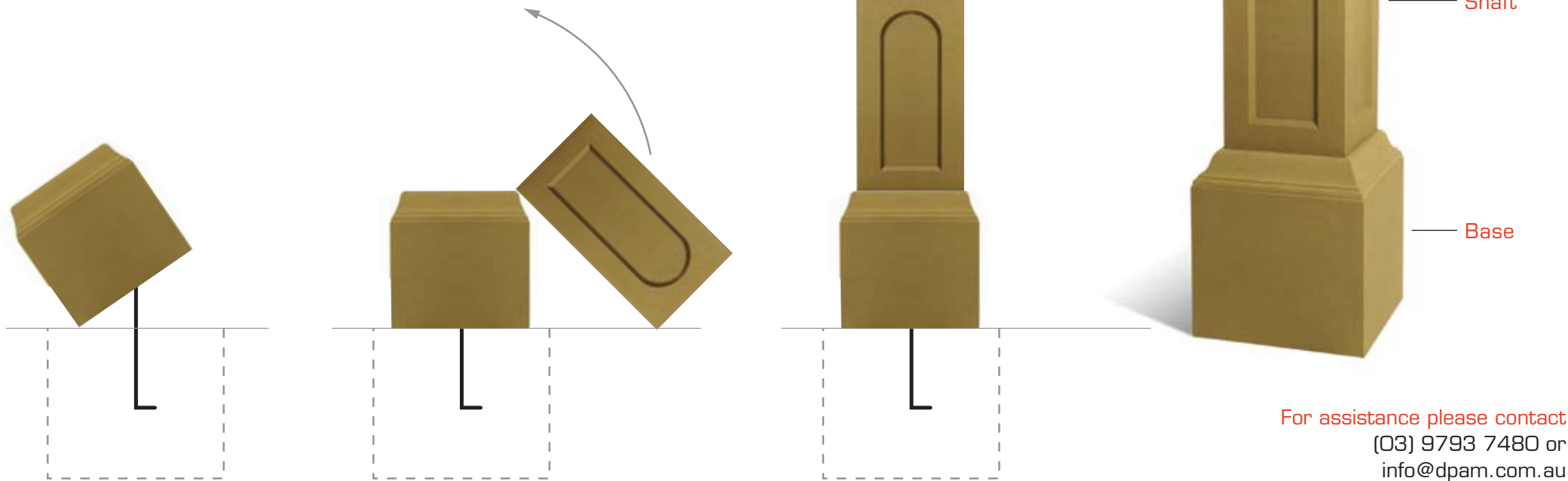

For assistance please contact
(03) 9793 7480 or
info@dpam.com.au